

INTRODUCTION

The QuikSert turbine flow meter is designed with wear-resistant moving parts to provide trouble-free operation and long service life. The QuikSert meter repair kit is designed for easy field service of a damaged flow meter, rather than replacing the entire flow meter. Repair parts are constructed of stainless steel alloy and tungsten carbide.

Each turbine meter repair kit is factory calibrated to ensure accuracy throughout the entire flow range. Each kit is complete and includes a new K-factor, which is the calibrated number of pulses generated by each gallon of liquid. This K-factor will be used to recalibrate the monitor, or other electronics, to provide accurate output data.

NOTE: If the meter repair kit part number ends in *NCC* (no calibration), it was not factory calibrated. For these repair kits, use the nominal K-factor supplied.

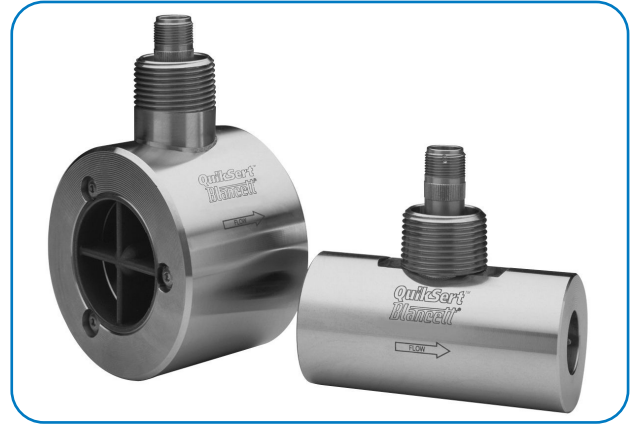

REPAIR KIT PART NUMBER INFORMATION

Repair Kit Part Number	Flow Meter Size	Part Number
B253-102	3/8 in. × 1 in.	B131-038
B253-105	1/2 in. × 1 in.	B131-050
B253-108	3/4 in. × 1 in.	B131-075
B253-109	7/8 in. × 1 in.	B131-088
B253-112	1 in. × 1 in.	B131-100
B253-205	1/2 in. × 2 in.	B132-050
B253-208	3/4 in. × 2 in.	B132-075
B253-209	7/8 in. × 2 in.	B132-088
B253-212	1 in. × 2 in.	B132-100
B253-216	1-1/2 in. × 2 in.	B132-150
B253-220	2 in. × 2 in.	B132-200
B253-330	3 in. × 3 in.	B133-300
B253-440	4 in. × 4 in.	B134-400
B253-660	6 in. × 6 in.	B136-600
B253-880	8 in. × 8 in.	B138-800
B253-990	10 in. × 10 in.	B139-900
B111109	Standard Magnetic Pickup	All Meter Sizes

TURBINE METER REMOVAL

⚠ WARNING

HIGH PRESSURE LEAKS ARE DANGEROUS AND MAY CAUSE PERSONAL INJURY. MAKE SURE THAT FLUID FLOW HAS BEEN SHUT OFF AND PRESSURE IN THE LINE RELEASED BEFORE ATTEMPTING TO REMOVE THE METER.

Disassembly

1. See [Figure 1 on page 3](#) and [Figure 2 on page 3](#) for relative positions of repair kit components.
2. Remove the magnetic pickup from the meter body to avoid damage during repair.
3. Remove the retaining ring from one end of the meter.

NOTE: Meters 2 inches and larger have retaining screws.

4. Remove the rotor support from the body. If the rotor support is jammed in the body, use a pair of pliers or vise grips to break the rotor support free.
5. Remove the rotor.
6. Remove the retaining ring from the opposite side of the meter.

NOTE: Meters 2 inches and larger have retaining screws.

7. Remove the second rotor support.

Installing the New Kit

IMPORTANT

Before reassembly, note that an arrow is cast or engraved on each component (see note below). The arrow indicates the direction of flow. The meter must be reassembled with arrowheads pointed in the direction of the fluid flow. The arrows are to be oriented in the UP position on both rotor supports. The magnetic pickup side of the body signifies the UP position. This is the position at which the repair kit was calibrated. Use this position for meter accuracy.

[Figure 1 on page 3](#) and [Figure 2 on page 3](#) show the proper alignment and orientation of the repair kits.

NOTE: Fractional size (3/8 in., 1/2 in. and 3/4 in.) rotors do not contain a cast or engraved arrow. However, a colored cap is provided on the downstream side of the rotor shaft to indicate flow direction. Remove this cap before assembly, noting flow direction.

1. Install one of the rotor supports into the body bore, noting the orientation of the arrow.
2. Secure a retaining ring in the groove provided. Be sure that retaining rings are completely installed in each groove.

NOTE: Meters 2 inches and larger will have retaining screws on both ends of the meter (see [Figure 2](#)).

3. Insert the rotor and second rotor support in the opposite side of the body, noting the orientation of the arrow.
4. Secure the second retaining ring in the opposite groove.

NOTE: Meters 2 inches and larger meters will have retaining screws on both ends of the meter (see [Figure 2](#)).

5. Check the meter by blowing air through the assembly. If the rotor does not turn freely, disassemble the meter and check for anything that would obstruct movement of the rotor.

⚠ CAUTION

EXCESS AIR PRESSURE MAY DAMAGE THE ROTOR AND BEARINGS BY OVER SPINNING.

6. Install the magnetic pickup.

NOTE: At this time, the electronics will need recalibration. Refer to the product user manual. If you have any questions on recalibration, contact Badger Meter, Inc. or the manufacturer of the associated electronics.

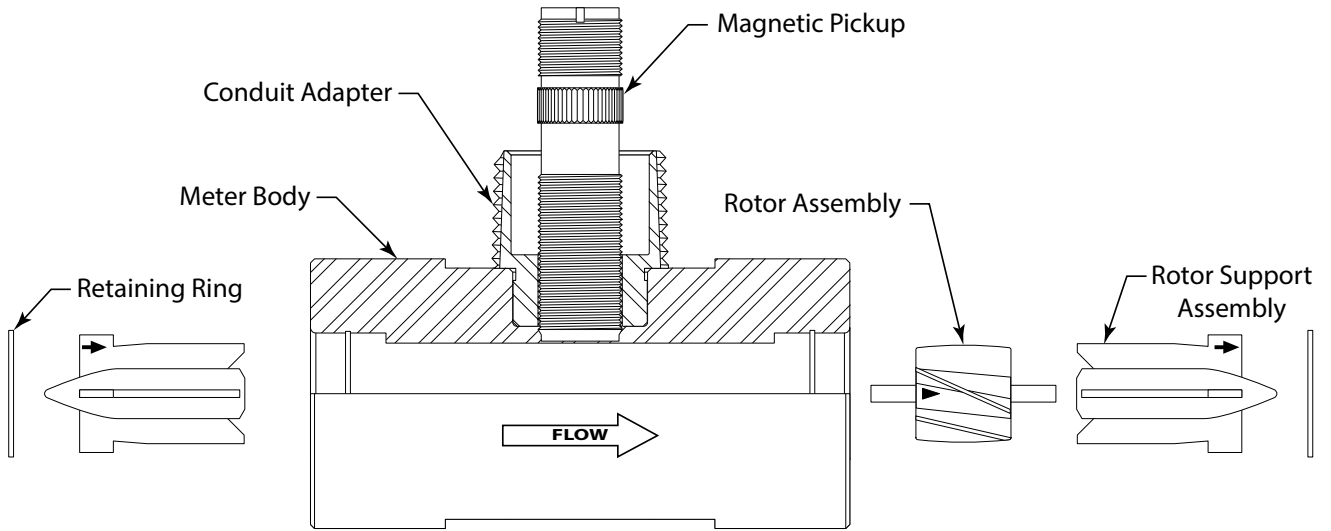

Figure 1: Relative positions of internal components for all QuikSert meter sizes B131-038 through B131-100

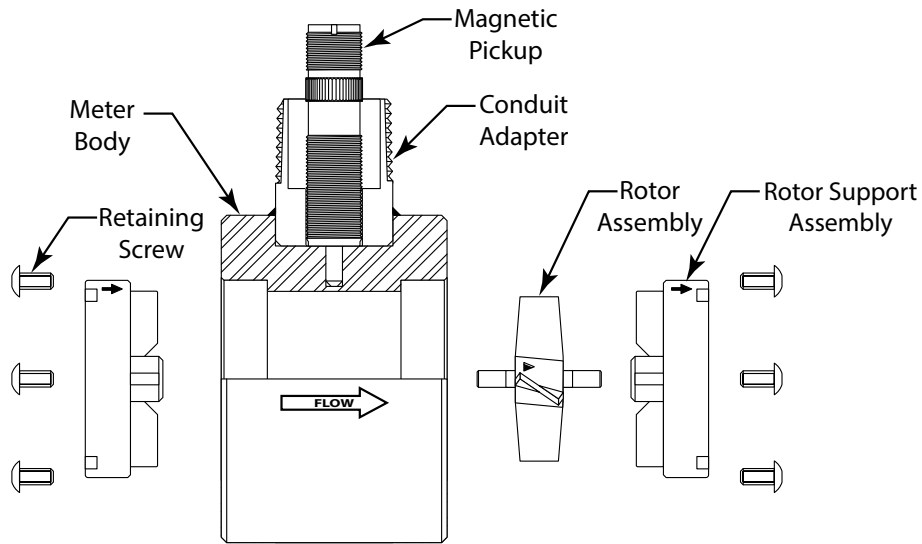

Figure 2: Relative positions of internal components for all QuikSert meter sizes B132-050 through B139-900

Control. Manage. Optimize.

Blancett is a registered trademarks of Badger Meter, Inc. Other trademarks appearing in this document are the property of their respective entities. Due to continuous research, product improvements and enhancements, Badger Meter reserves the right to change product or system specifications without notice, except to the extent an outstanding contractual obligation exists. © 2021 Badger Meter, Inc. All rights reserved.

www.badgermeter.com