



Turbine Flow Meter

Model 1200



TRB-UM-00290-EN-09 (June 2021)

User Manual

CONTENTS

Scope of This Manual	3
Unpacking and Inspection	3
Safety	3
Terminology and Symbols	3
Considerations	3
Introduction.	4
Operating Principle	4
Installation.	5
Wiring Diagram.	7
Operational Startup.	8
Part Number Information	8
Meter with pickups	8
Meter only (no pickups)	8
Troubleshooting Guide.	9
Specifications.	10

SCOPE OF THIS MANUAL

This manual is intended to help you get the Model 1200 turbine flow meter up and running quickly.

IMPORTANT

Read this manual carefully before attempting any installation or operation. Keep the manual accessible for future reference.



UNPACKING AND INSPECTION

Upon opening the shipping container, visually inspect the product and applicable accessories for any physical damage such as scratches, loose or broken parts, or any other sign of damage that may have occurred during shipment.

NOTE: If damage is found, request an inspection by the carrier's agent within 48 hours of delivery and file a claim with the carrier. A claim for equipment damage in transit is the sole responsibility of the purchaser.

SAFETY

Terminology and Symbols

	Indicates a hazardous situation, which, if not avoided, is estimated to be capable of causing death or serious personal injury.
	Indicates a hazardous situation, which, if not avoided, could result in severe personal injury or death.
	Indicates a hazardous situation, which, if not avoided, is estimated to be capable of causing minor or moderate personal injury or damage to property.

Considerations

The installation of the Model 1200 flow meter must comply with all applicable federal, state, and local rules, regulations, and codes.

WARNING

EXPLOSION HAZARD - SUBSTITUTION OF COMPONENTS MAY IMPAIR SUITABILITY FOR CLASS I, DIVISION 2.

AVERTISSEMENT

RISQUE D'EXPLOSION - LA SUBSTITUTION DE COMPOSANTS PEUT RENDRE CEMATÉRIEL INACCEPTABLE POUR LES EMPLACEMENTS DE CLASSE I, DIVISION 2.

WARNING

DO NOT CONNECT OR DISCONNECT EITHER POWER OR OUTPUTS UNLESS THE AREA IS KNOWN TO BE NON-HAZARDOUS.

AVERTISSEMENT

RISQUE D'EXPLOSION. NE PAS DÉBRANCHER TANT QUE LE CIRCUIT EST SOUSTENSION, À MOINS QU'LL NE S'AGISSE D'UN EMPLACEMENT NON DANGEREUX.

IMPORTANT

Not following instructions properly may impair safety of equipment and/or personnel.

INTRODUCTION

The Blancett Model 1200 in-line turbine flow meter was engineered for applications in highly corrosive environments. Developed for use in petrochemical and other process industries with liquid chemical flows, the Model 1200 turbine meter provides accuracy and durability in aggressive industrial environments. The meter features a 303 stainless steel body and internal wetted parts, with two type-440 stainless steel ball bearings.

OPERATING PRINCIPLE

Fluid entering the meter passes through the inlet flow conditioner, which reduces its turbulent flow pattern and improves the fluid's velocity profile. The fluid then passes through the turbine, causing the turbine to rotate at a speed proportional to the fluid velocity. As each turbine blade passes through the magnetic field, the blade generates an AC voltage pulse in the pickup coil at the base of the magnetic pickup (see *Figure 1*). These pulses produce an output frequency proportional to the volumetric flow through the meter. The output frequency represents flow rate and/or totalization of fluid passing through the turbine flow meter.

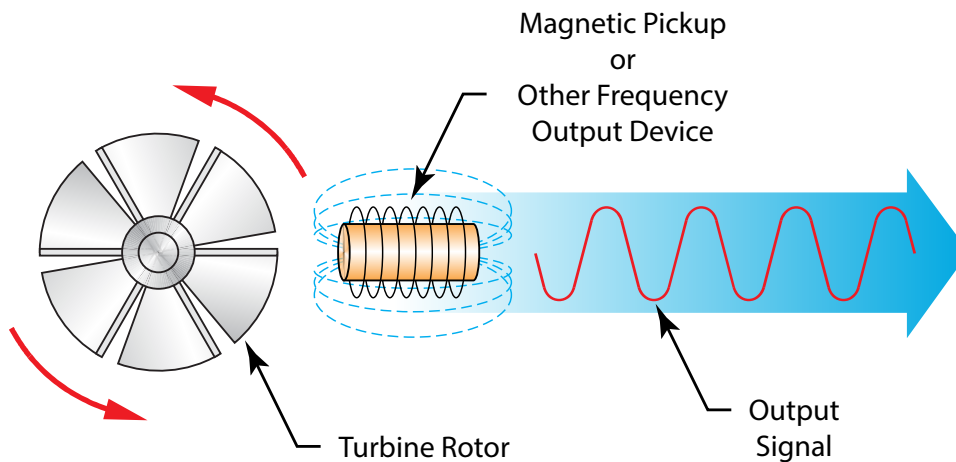

Figure 1: Schematic illustration of electric signal generated by rotor movement

INSTALLATION

⚠ WARNING

PRESSURE IN EXCESS OF ALLOWABLE RATING MAY CAUSE THE HOUSING TO BURST AND CAUSE SERIOUS PERSONAL INJURY.

1. Check the inside of the flow meter for any foreign material.
2. Check the turbine rotor to make sure it spins freely.
3. Check the fluid lines and remove any debris.
4. Install the flow meter with the flow arrow, which is etched on the exterior of the meter body, pointing in the direction of fluid flow.
5. Install the meter horizontally with the conduit adapter facing upward.
6. Thread a magnetic pickup into the conduit adapter. Tighten the pickup finger tight without forcing.
7. Secure with a lock nut if supplied.
8. Install conduit or other fittings suitable for the installation area onto the conduit adapter hub on the flow meter.

All Blancett Model 1200 turbine meters use stainless steel construction materials. Make sure that the operating fluid is compatible with these materials. Incompatible fluids can cause deterioration of internal components and reduce the accuracy of the meter.

The measured liquid should be free of any large particles that may inhibit rotation of the turbine blades. If particles are present, install a mesh strainer upstream before operating the flow meter. See *Table 1* for strainer recommendations.

Part Number	Size	Strainer Mesh	Clearance (in.)
B121-225	1/4 in. (6.35 mm)	60	0.0092
B121-250	1/2 in. (12.7 mm)	60	0.0092
B121-275	3/4 in. (19.05 mm)	60	0.0092

Table 1: Strainer recommendations

Install a bypass line to accommodate inspection and repair without interrupting flow. See *Figure 2 on page 6*. If a bypass line cannot be used, install all control valves or restrictions that may cause the liquid to flash downstream of the flow meter. Install air eliminators to make sure that the meter is not incorrectly measuring entrained air or gas.

⚠ CAUTION

STRIKING AN EMPTY METER WITH HIGH VELOCITY FLOW STREAM CAN CAUSE DAMAGE.

Install a minimum length of 10 pipe diameters of straight pipe on the upstream side, and 5 diameters on the downstream side of the flow meter. The piping should be the same size as the meter bore or threaded port size.

Do not install the flow meter or connection cable close to electric motors, transformers, sparking devices or high voltage lines. Do not place connecting cable in the same conduit with wires that furnish power for such devices. These devices can induce false signals in the flow meter coil or cable, causing the meter to read inaccurately.

If problems arise with the flow meter, see *Troubleshooting Guide on page 9*. Consult the factory with additional issues.

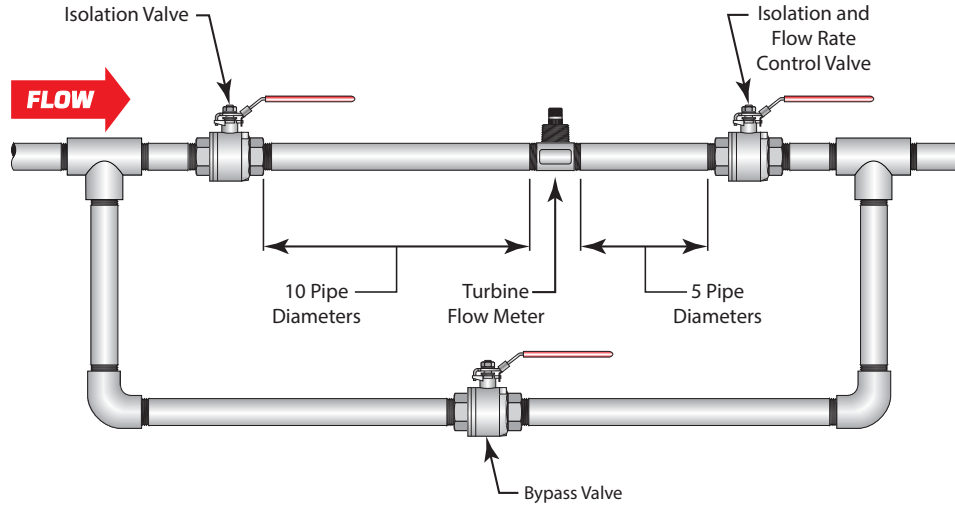

Figure 2: Meter installation using a bypass line

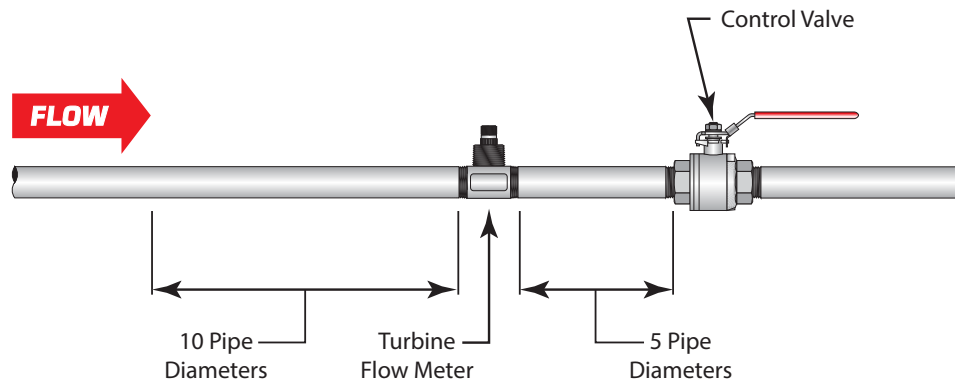

Figure 3: Meter installation without using a bypass line

WIRING DIAGRAM

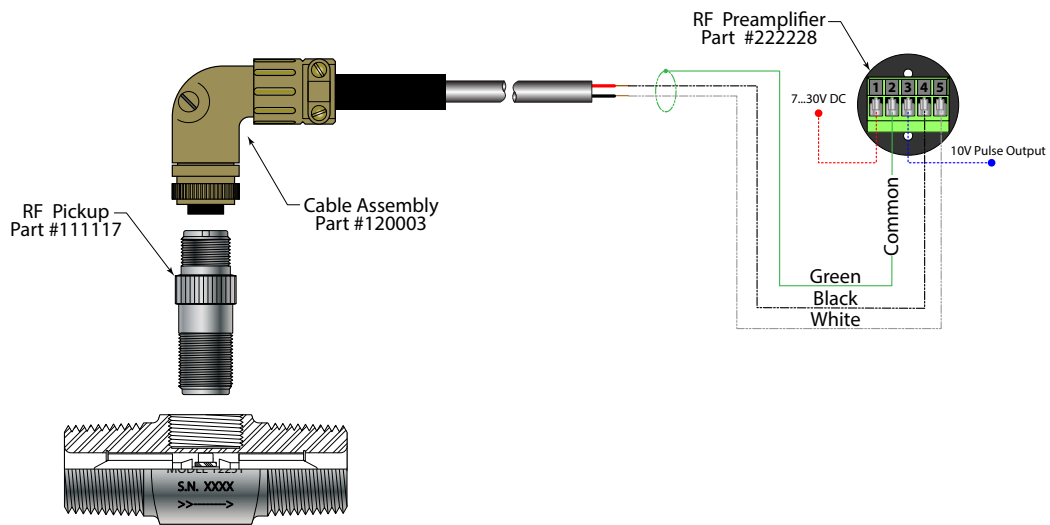

Illustration Using
Model 121-225 Meter

Figure 4: Wiring diagram with RF pickup, cable assembly and preamplifier

Terminal	Description	Notes
1	Power	7...30V DC
2	Common	Power return
3	Output signal	10V Square wave
4	Input	RF pickup (1 millihenry)
5	Input	RF pickup (1 millihenry)

OPERATIONAL STARTUP

⚠ WARNING

MAKE SURE TO SHUT OFF FLUID FLOW AND RELEASE THE PRESSURE IN THE LINE BEFORE ATTEMPTING TO INSTALL THE METER IN AN EXISTING SYSTEM.

1. After meter installation, close the isolation valves and open the bypass valve. Allow the liquid to flow through the bypass valve for sufficient time to eliminate any air or gas in the flow line.

⚠ CAUTION

STRIKING AN EMPTY METER WITH HIGH VELOCITY FLOW STREAM CAN CAUSES DAMAGE.

2. Open the upstream isolating valve slowly to eliminate hydraulic shock while charging the meter with the liquid.
3. Open the valve to the fully open.
4. Open the downstream isolating valve to permit the meter to operate.
5. Close the bypass valve to a fully closed position.
6. Adjust the downstream valve to provide the required flow rate through the meter.

NOTE: The downstream valve may be used as a control valve.

PART NUMBER INFORMATION

Meter with pickups

Part Number	Bore Size	End Connections	Max PSI	Flow Ranges	Strainer Mesh	Approx. K-factor Pulses/Gal	Weight	End to End Length
				gpm (lpm)				
B121-225	1/4 in.	1/2 in. Male NPT	4000	0.25...2.5 (0.95...9.46)	60	29,000...33,000	—	—
B121-250	1/2 in.	1/2 in. Female NPT	4000	0.75...7.5 (2.84...28.39)	60	8500...9500	—	—
B121-275	3/4 in.	1 in. Male NPT	4000	2.5...25 (9.46...94.64)	60	2800...3000	—	—

Meter only (no pickups)

Part Number	Bore Size	End Connections	Max PSI	Flow Ranges	Strainer Mesh	Approx. K-factor Pulses/Gal	Weight	End to End Length
				gpm (lpm)				
B121227	1/4 in.	1/2 in. Male NPT	4000	0.25...2.5 (0.95...9.46)	60	29,000...33,000	—	—
B121251	1/2 in.	1/2 in. Female NPT	4000	0.75...7.5 (2.84...28.39)	60	8500...9500	—	—
B121276	3/4 in.	1 in. Male NPT	4000	2.5...25 (9.46...94.64)	60	2800...3000	—	—

TROUBLESHOOTING GUIDE

Issue	Possible Cause	Remedy
Meter indicates higher than actual flow rate	Cavitation Debris on rotor support	Increase back pressure Clean meter
Meter indicates lower than actual flow rate	Debris on rotor Worn bearing Viscosity higher than calibrated	Clean meter and add filter Replace meter Change temperature; change fluid; recalibrate meter
Erratic system indication, meter alone works well	Ground loop in shielding	Ground shield one place only
Indicator shows flow when shut off	Mechanical vibration causes rotor to oscillate without turning	Isolate meter
No flow indication, full or partial open position	Fluid shock, full flow into dry meter or impact caused bearing separation	New bearing required Move to location where meter is full of fluid on startup
Erratic indication at low flow, good indication at high flow	Low instrument sensitivity; 10 mV rms turbine signal is being lowered by loading of electronics or instrumentation cannot sense low level signals	Amplify signal
No flow indication	Faulty pickup	Replace pickup, recalibrate as necessary
Indicates lower flow over entire range	Bypass flow, leak	Eliminate bypass valves, leak Repair or replace faulty solenoid valves
Meter indicating high flow, upstream piping at meter smaller than meter bore	Fluid jet impingement on rotor, critical in gas	Change piping
Opposite effects of above	Viscosity lower than calibrated	Change temperature, change fluid or recalibrate meter
Mass flow indication wrong	Wrong fluid density (critical in gas)	Check fluid, electronics
Erratic or wrong indication of flow	Loose pickup	Tighten pickup
Does not repeat at low flows Repeats at high flow	System resolution readability	Increase resolution

SPECIFICATIONS

Materials of Construction	Body	303 stainless steel
	Rotor	CD4MCU stainless steel
	Bearings	Two (2) type-440 stainless steel ball bearings
	Rotor Shaft	303 stainless steel
	Rotor Support	303 stainless steel
	Housing	Epoxy encapsulated module
Operating Temperature	Meter	-60...350° F (-51...177° C)
	Module	-20...160° F (-7...71° C)
	Pickup	-150...325° F (-101...162° C)
Pressure Rating	4000 psi (276 bar) maximum	
End Connection	NPT male, NPT female	
Turndown Ratio	—	
Accuracy	±1.0% of reading	
Repeatability	±0.1%	
Calibration	MIL-PRF-7024E, Type II (NIST traceable calibration)	
Pickup	—	
Certification	—	
RF Preamplifier	Input Signal	1 millihenry carrier pickup
	Output Signal	10V peak to peak square wave
Power	7...30V DC	
Distance Specification	50 ft maximum between pickup and RF preamplifier 1000 ft maximum between preamplifier and receiving unit	
Electrical Connection	Terminal strip	

INTENTIONAL BLANK PAGE

Control. Manage. Optimize.

Blancett is a registered trademark of Badger Meter, Inc. Other trademarks appearing in this document are the property of their respective entities. Due to continuous research, product improvements and enhancements, Badger Meter reserves the right to change product or system specifications without notice, except to the extent an outstanding contractual obligation exists. © 2021 Badger Meter, Inc. All rights reserved.

www.badgermeter.com