

INTRODUCTION

The 1100 Series turbine flow meter uses wear-resistant moving parts to provide trouble-free operation and long service life. The 1100 Series meter repair kit is designed for easy field service of a damaged flow meter, rather than replacing the entire flow meter. Repair parts are constructed of stainless steel alloy and tungsten carbide.

Each turbine meter repair kit is factory calibrated for accuracy throughout the entire flow range. Each kit is complete and includes a new K factor, which is the calibrated number of pulses generated by each gallon of liquid. This K factor will be used to recalibrate the monitor, or other electronics, to provide accurate output data.

NOTE: If the meter repair kit part number ends in NCC (no calibration), it was not factory calibrated. For these repair kits, use the nominal K factor supplied.

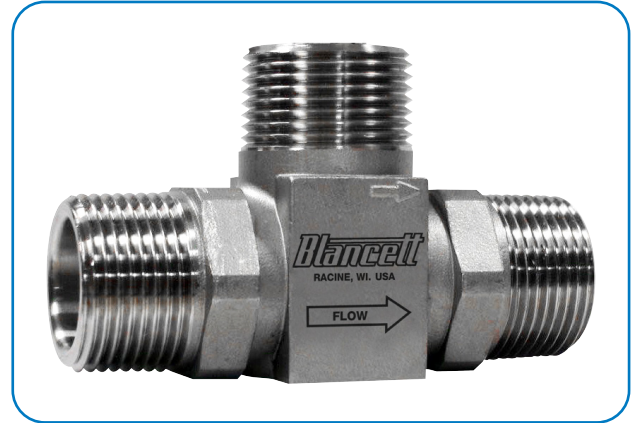

REPAIR KIT PART NUMBER INFORMATION

Flow Meter Size	Replacement Kit Fits Meter Part Number	Repair Kit Part Number
3/8 in.	B110-375, B110-375-1/2	B251-102
1/2 in.	B110-500, B110-500-1/2	B251-105
3/4 in.	B110-750, B110-750-1/2	B251-108
7/8 in.	B110-875	B251-109
1 in.	B111-110	B251-112
1-1/2 in.	B111-115	B251-116
2 in. Low	B111-121	B251-116
2 in.	B111-120	B251-120
3 in.	B111-130	B251-131
4 in.	B111-140	B251-141
6 in.	B111-160	B251-161
8 in.	B111-180	B251-181
10 in.	B111-200	B251-200
Standard Magnetic Pickup	All Meter Sizes	B111109

Table 1: Repair kit part numbers

TURBINE ASSEMBLY REMOVAL

⚠️ WARNING

HIGH-PRESSURE LEAKS ARE DANGEROUS AND MAY CAUSE PERSONAL INJURY. MAKE SURE TO SHUT OFF FLUID FLOW AND RELEASE RESIDUAL PRESSURE IN THE LINE BEFORE ATTEMPTING TO REMOVE THE METER.

⚠️ AVERTISSEMENT

LES FUITES À HAUTE PRESSION SONT DANGEREUSES ET PEUVENT CAUSER LE DOMMAGE CORPOREL. ASSUREZ-VOUS QUE LE FLUX DE FLUIDE A ÉTÉ COUPÉ ET DE LA PRESSION DANS LA LIGNE A ÉTÉ LIBÉRÉE AVANT D'ESSAYER D'ENLEVER LE MÈTRE.

Disassembly

1. Refer to [Figure 1](#), [Figure 2](#) and [Figure 3](#) for relative positions of repair kit components.
2. Remove the magnetic pickup from the meter body to avoid damage during repair.
3. Remove the retaining ring from one end of the meter.
4. Remove the rotor support from the body. If the rotor support is jammed in the body, use a pair of pliers or vise-grips to break the rotor support free.
5. The rotor may also be removed at this time.

NOTE: 4 in. and larger meters have two retaining rings (one on either side of the rotor) that require removal before the rotor can be removed (see [Figure 3](#)).

6. Remove the retaining ring from the opposite side of the meter.
7. Remove the second rotor support.

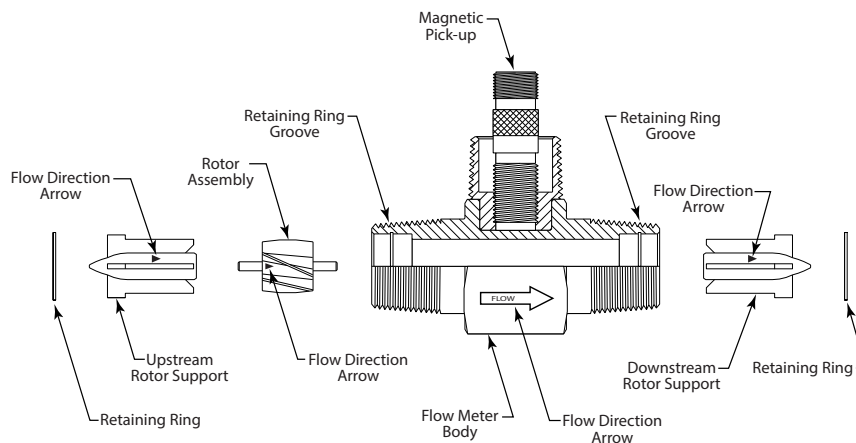

Figure 1: Component positions for B110-375...B111-115 and B111-121

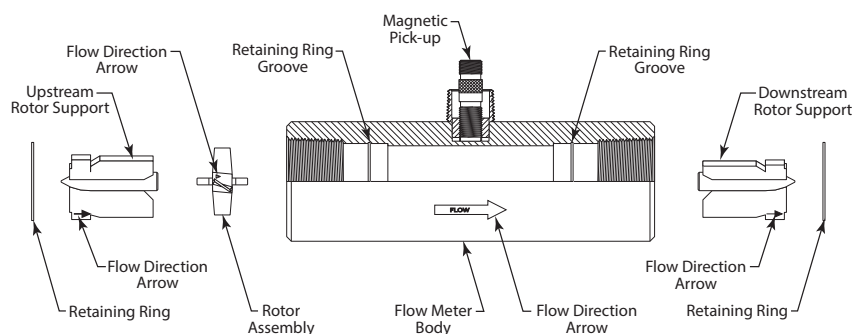

Figure 2: Component positions for B111-120 and B111-130

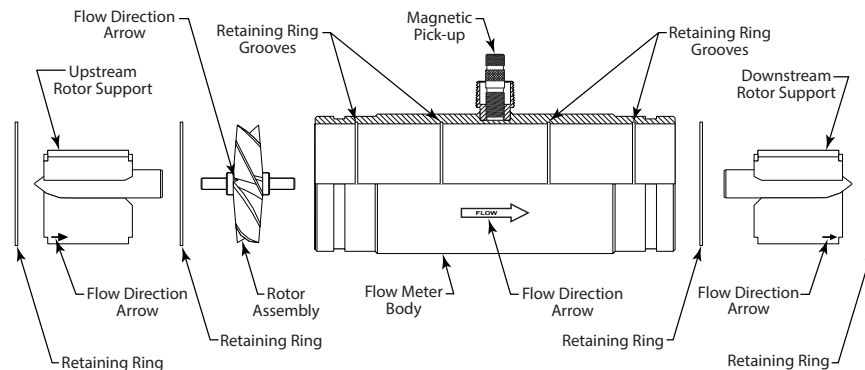

Figure 3: Component positions for B111-140 and B111-200

New Turbine Kit Installation

IMPORTANT

Before reassembly, note that an arrow is cast or engraved on each component. The arrow indicates the primary flow direction. When reassembled, the arrowheads must point in the direction of the fluid flow. The arrows must also be oriented in the up position on both rotor supports. The magnetic pickup side of the body signifies the up position. Performance of repair kit calibration is in the up position. Reinstallation of the repair kit in the up position ensures continuation of accurate measurements. [Figure 1](#), [Figure 2](#), and [Figure 3](#) show the proper alignment and orientation of the repair kits.

NOTE: Fractional size (3/8 in., 1/2 in. and 3/4 in.) rotors do not contain a cast or engraved arrow. However, a colored cap on the downstream side of the rotor shaft indicates flow direction. Remove this cap before assembly, noting flow direction.

1. Install one of the rotor supports into the body bore, noting the orientation of the arrow.
2. Secure a retaining ring in the groove provided. Check for complete installation of retaining rings in each groove.

NOTE: 4 in. and larger meters have a retaining ring at both ends of the rotor (see [Figure 3](#)).

3. Insert the rotor and second rotor support in the opposite side of the body, noting the orientation of the arrow.
4. Secure the second retaining ring in the opposite groove, using the same procedure as in step 2 above.

CAUTION

EXCESS AIR PRESSURE MAY DAMAGE THE ROTOR AND BEARINGS BY OVER SPINNING.

ATTENTION

LA PRESSION ATMOSPHERIQUE EXCESSIVE PEUT ENDOMMAGER LE ROTOR ET LES ROULEMENTS PRÈS AU-DESSUS DE LA ROTATION.

5. Check the meter by lightly puffing air through the assembly. If the rotor does not turn freely, disassemble the meter and remove anything that might obstruct movement of the rotor.

NOTE: At this time, electronics require recalibration. Refer to the display's user manual. If there are any questions on recalibration, contact Badger Meter or the manufacturer of the associated electronics.

6. Install the magnetic pickup.

PART NUMBER INFORMATION

Part Number	Meter Size	End-to-End Length		End Connection	Flow Ranges		
		inches	mm		gpm	bpd	m ³ /d
B110-375-1/2	3/8 in.	3	76.2	1/2 in. Male NPT	0.6...3.0	20...100	3.3...16
B110-500-1/2	1/2 in.	3	76.2	1/2 in. Male NPT	0.75...7.5	25...250	4.1...41
B110-750-1/2	3/4 in.	3	76.2	1/2 in. Male NPT	2...15	68...515	10.9...81.75
B110-375	3/8 in.	4	101.6	1 in. Male NPT	0.6...3.0	20...100	3.3...16
B110-500	1/2 in.	4	101.6	1 in. Male NPT	0.75...7.5	25...250	4.1...41
B110-750	3/4 in.	4	101.6	1 in. Male NPT	2...15	68...515	10.9...81.75
B110-875	7/8 in.	4	101.6	1 in. Male NPT	3...30	100...1000	16...160
B111-110	1 in.	4	101.6	1 in. Male NPT	5...50	170...1700	27.25...272.5
B111-115	1-1/2 in.	6	152.4	1-1/2 in. Male NPT	15...180	515...6000	82...981
B111-121	2 in. Low	6	152.4	2 in. Male NPT	15...180	515...6000	82...981
B111-120	2 in.	10	254	2 in. Female NPT	40...400	1300...13,000	218...2180
B111-130	3 in.	12-1/2	317.5	3 in. Grooved End	60...600	2100...21,000	327...3270
B111-140	4 in.	12	304.8	4 in. Grooved End	100...1200	3400...41,000	545...6540
B111-160	6 in.	12	304.8	6 in. Grooved End	200...2500	6800...86,000	1090...13,626
B111-180	8 in.	12	304.8	8 in. Grooved End	350...3500	12,000...120,000	1363...19,076
B111-200	10 in.	12	304.8	10 in. Grooved End	500...5000	17,000...171,000	2725...27,252

Control. Manage. Optimize.

Blancett is a registered trademarks of Badger Meter, Inc. Other trademarks appearing in this document are the property of their respective entities. Due to continuous research, product improvements and enhancements, Badger Meter reserves the right to change product or system specifications without notice, except to the extent an outstanding contractual obligation exists. © 2021 Badger Meter, Inc. All rights reserved.